



# TRAVIS COUNTY

Fire Marshal's Office

5555 Airport Blvd. Suite 400, Austin, TX 78751

(512) 854-4621 | fire-marshal@traviscountytexas.gov

## TENT AND OTHER MEMBRANE STRUCTURE SUBMITTAL GUIDELINES

The Travis County Fire Marshal's Office requires a permit for any tent or other membrane structure that meets the following requirements. All permitted tents shall meet the requirements outlined in this document.

- Tents with sides or membrane structure having an area over 400 square feet.
- Single tent having an area over 700 square feet without sides
- Multiple tents placed side by side without a 12' break clearance exceeding 700 square feet.

### Pop-up Tent Options

#### Option 1:

The pop-up tents can be attached in clusters of three in any configuration with a 10' minimum separation distance on all sides.

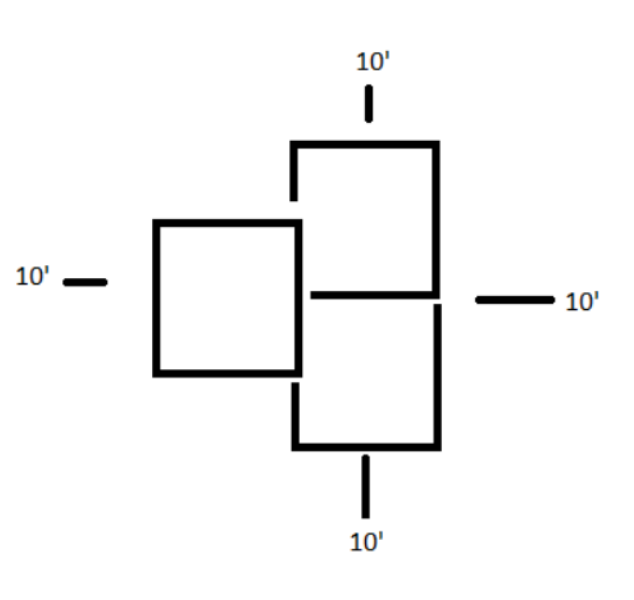

**Option 2:**

- A. The pop-up tents can be attached side by side as long as no sides are placed on them and product is not stacked creating a wall or barrier and the tents do not measure over 700 square foot. There would need to be a minimum of 10' separation provided to the front and rear.

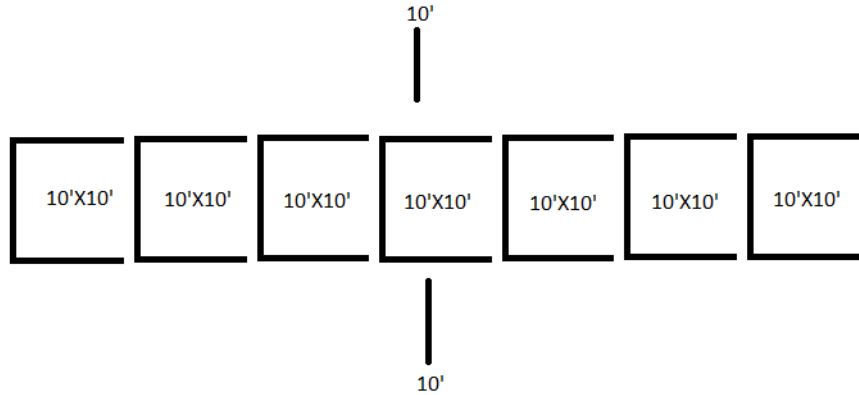

- B. If you want to add over 700 square foot then you must have 12' separation in front and rear and sides before adding additional square footage.

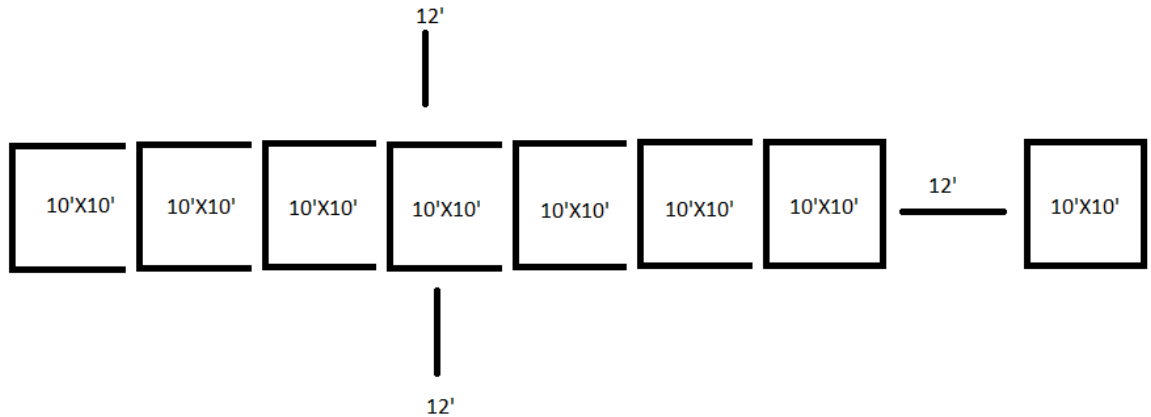

**Option 3:** Combination of 1 and 2.

**Plan Submittal Requirements for Tent Installer**

- Submit a permit request for **EACH** tent(s) that requires permitting at [TCFMOPERMITS.COM](http://TCFMOPERMITS.COM)
- Identify anchoring locations along with documentation of structural stability

- Provide a copy of certification from an approved testing laboratory shall be provided indicating that all structures and accessories described above are composed of flame-resistant material or have been treated with a flame retardant in an approved manner and meet the requirements for flame resistance as determined in accordance with NFPA 701, and that such flame resistance is effective for the period specified by the permit.

**Certificate of Flame Resistance**

Registered Application Number <b>F 4 1 9 . 0 1</b>		ISSUED BY Central Tent Santa Clarita, CA	Date of Manufacture: 2/10/12
---	---	--	---------------------------------

This is to certify that the materials described have been flame retardant treated (or are inherently nonflammable).

FOR Adam's Canopy ADDRESS 3508-A E. Cesar Chavez  
 CITY Austin STATE TX ZIP 78702

**Certification is hereby made that:**  
 The articles described on this certificate have been treated with a flame-retardant fabric or material registered and approved by the State of California Fire Marshal. The article meets the NFPA-701 Flame retardant standard.

Trade name of flame-resistant fabric or material used: Lam-Tex Reg. F419.01  
 The Flame Retardant Process Used will not be Removed by Washing.

Type, Color, and weight of canvas / vinyl: White, Vinyl, 15oz. Blackout

Description: 1- 20x20 Olive Drab Top, >>1pc << 15oz Blackout - Standard Top  
 3- Sidewall 8x20 Olive Drab -15oz blackout - SOLID

Name of Applicator of Flame Resistant Finish: California Combining Corporation	SIGNATURE  CENTRAL TENT MANUFACTURER
---	---

- Labels shall be permanently affixed to all temporary membrane structures, tents or canopies bearing the identification of size and fabric or material type.



- Provide a site plan that indicates location of tent, canopy or temporary membrane structure in relation to streets, alleys, roads, property lines, buildings and vehicle parking.

Temporary membrane structures, tents, canopies, air-supported, or air-inflated structures shall not be located within 20 feet of:

- Lot lines, streets, alleys, buildings, parked vehicles or internal combustion engines.
- Open flame or other devices emitting flame, fire or heat or any flammable or combustible liquids, gas, charcoal or other cooking device or any other unapproved devices while open to the public, unless approved by the Fire Marshal's Office.
- For the purpose of determining required distances, support ropes and guy wires shall be considered as part of the temporary membrane structure, tent or canopy.

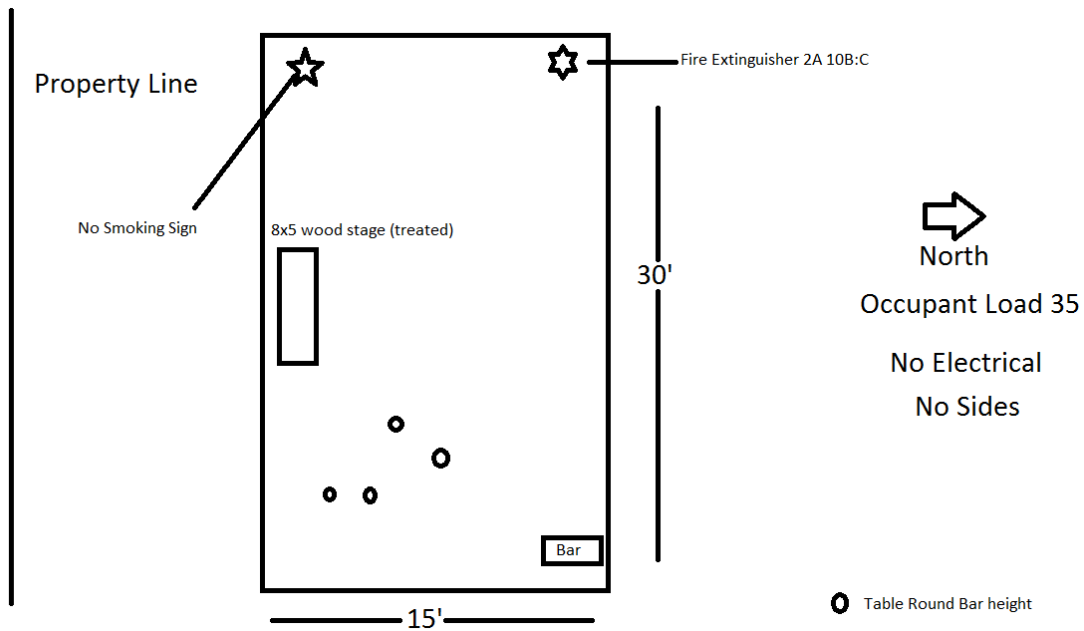

### Plan Submittal Requirements for Tent User

- Submit a floor plan indicating details of the event (layout of event), the approximate occupant load expected, exiting arrangement and seating capacity and arrangement.
- Identify locations of any electrical and egress illumination
- List any special hazards such as vehicle displays, candles, or pyrotechnics
- Ensure a continuous and unobstructed way of exit travel from all points in the structure which provides a route to the exterior.
- Combustible vegetation and waste shall be cleared from an area within 30 feet of temporary membrane structures, tents, canopies, air-supported, or air-inflated structures.

## Required Fire Protection & Life Safety Measures

- Post "No Smoking" signs and provide receptacle outside at each entrance.
- ABC type dry chemical fire extinguishers shall be provided as needed to maintain a maximum travel distance of 75 feet from all areas of the structure to an extinguisher. Extinguishers shall have a minimum rating of 2-A, 10-B:C.
- Hay, straw, shavings or similar combustible materials shall not be located within any tent or air-supported structure containing assembly occupancy, except the materials necessary for the daily feeding and care of animals. Sawdust and shavings utilized for a public performance or exhibit shall not be prohibited provided the sawdust and shavings are kept damp.
- Combustible trash shall be removed at least once a day from the structure during the period the structure is occupied by the public and shall be stored in approved containers until removed from the premises. Combustible materials shall not be permitted under stands or seats at any time.
- Open flame or other devices emitting flame, fire or heat or any flammable or combustible liquids, gas, charcoal or other cooking device or any other unapproved devices shall not be permitted inside structures while open to the public unless approved by the Fire Marshal's Office.

**ALL REQUESTED INFORMATION OUTLINED  
IN THIS DOCUMENT MUST BE SUBMITTED  
TO [TCFMOPERMITS.COM](https://www.tcfmopermits.com).**

## **TRAVIS COUNTY FIRE MARSHAL'S OFFICE**

5555 Airport Blvd. Suite 400,  
Austin, Texas, 78751

(512) 854-4621  
[fire.marshall@traviscountytexas.gov](mailto:fire.marshall@traviscountytexas.gov)